

Canadian Pony Club



NATIONAL DRESSAGE RULES

Dressage Rules

Rules that apply to running Dressage Events within the Canadian Pony Club for both Regional and National events. Changes highlighted in yellow for current year. Revised April 2021. See General Rules for additional supplemental rules that apply to the disciplines. **Changes for 2021 highlighted in yellow.**



CANADIAN PONY CLUB

NATIONAL DRESSAGE RULES

2021

Loyalty

Character

Sportsmanship

TABLE OF CONTENTS

The True Meaning of Dressage	2
Progressive Stages of Proficiency.....	4
FEI Levels for Developing Riders	6
GUIDELINES GOVERNING CPC DRESSAGE COMPETITIONS.....	8
1 Introduction.....	8
2 CPC National Dressage Championship Competition.....	10
3 Qualifying for CPC National Dressage Championships	16
4 Regional Dressage Championships	17
5 Canadian Pony Club Dressage Competition Rules	21
6 Execution and Judging of Tests	23
7 Officials and Volunteers	29
8 Scoring.....	36
9 Canadian Pony Club Drill Team Rules	39
10 Canadian Pony Club Funding and Development	41
ORGANIZERS' HANDBOOK	42
Appendix A: Check List & Time Plan for Running a Dressage Competition	42
Appendix B: Arenas and Markers.....	48
Appendix C: Prize List Requirements	52
National / International Eligibility Chart	54
CPC REGIONAL Dressage Championships Turnout Score Sheet	56



CANADIAN PONY CLUB

NATIONAL DRESSAGE RULES

2021

Loyalty

Character

Sportsmanship

THE TRUE MEANING OF DRESSAGE

Dressage is the basis of athleticism in a horse, regardless of discipline. Strictly speaking, the word means “training”, with no specification as to what the purpose of that training should be. Originally applied to the training of a warhorse, it has been applied to all forms of horsemanship throughout the ages. The objective of the Canadian Pony Club in dressage is the education of the rider and a confident, relaxed horse happy in its work.

The competitive discipline known as dressage has only been formalized over the past one hundred years. The process of developing the horse as an athlete in order to have him perform to his best ability has been in place for several thousand years. Throughout that time there have been many outstanding horsemen who have been keen observers of equine behaviour and movement. They have each built upon the understanding of their predecessors to develop what is now known as a “classical” system for training horses. It is based upon knowledge of what is natural for a horse in real life. Acknowledging their behaviour, response to stimulus, and thought process is a necessary part of being able to create a bond between horse and human. Without that bond and mutual understanding, it is much more difficult to develop an athlete.

Over the past twenty odd centuries horsemen have understood that asking a horse to perform certain exercises aids in their development. Long before the twentieth century concept of “cross-training” was developed for humans, horsemen understood the concept for horses. Long, slow, gallops develop the respiratory and aerobic cardiac system as well as lower leg bone strength. Short bursts of gallop at high speeds (breezing or pipe opening) develop the anaerobic system. Appropriate flat work develops muscle strength (transitions), suppleness and flexibility (bending and lateral work), relaxation and obedience.

The exercises are the same for all horses. Bio-mechanically speaking, a horse is a horse. It is up to the horseman to decide to which degree every aspect of the horse is to be developed. Competitively, an event horse must retain the most speed and stamina, a jumper the biggest jump, and the dressage horse the most precisely controlled power. Yet they all need to retain some aspect of it all. Consider it a sliding scale with the eventer at one extreme and the modern dressage horse at the other. Train your horse past a certain point in dressage and he will end up developing muscles that interfere with his speed. Limit the strength training component of dressage in order to maintain the jump, and he loses the ability to lift himself up into the higher-level movements with the precision required for a dressage horse.

At some point, humans being humans, we decided to test our horsemanship. Combined training evolved out of modern military requirements. From this three-phase event evolved the sports of show jumping and dressage. Setting a standard of speed and jump is relatively easy, but competitive dressage is about strength and flexibility from a physical point of view. How to test it? It became clear that the same exercises that are used to develop a horse athletically, regardless of discipline, (circles, lateral work, transitions and changes of pace) could be used to



CANADIAN PONY CLUB

NATIONAL DRESSAGE RULES

2021

Loyalty

Character

Sportsmanship

test the progress of the horse along the sliding scale mentioned above. And so, the “dressage test” was born.

A test of the progress in the training of the horse using the standard movements that ALL horses use in their training in order to categorize their current athletic state.

A world class show hunter is schooling Second level movements. A top medal/equitation horse is schooling Third level movements with the carriage of a Second level horse. A world class eventer is probably schooling at home at Fourth level, and a world class jumper is probably working every day at about a Prix St. George level. The goal of most dressage riders is to develop their own skills to be able to school a horse to as high a level as they can, which would mean Grand Prix competitively, or being able to ask for “airs above the ground” just for the sheer joy of it.

In other words, anyone who schools a horse is already doing dressage, and dressage competition need not be limited to those who are planning to develop a “dressage” horse. Dressage competition is nothing more than a standardized method of judging the athletic development of a horse. So, go out there and try it. Challenge yourself and have fun with it.



CANADIAN PONY CLUB

NATIONAL DRESSAGE RULES

2021

Loyalty

Character

Sportsmanship

PROGRESSIVE STAGES OF PROFICIENCY

1. Entry

To demonstrate that the pony is obedient to the rider's aids, moving forward and beginning to develop rhythm. Ponies may be ridden in a simple snaffle or a kimberwick bit with the reins through the ring and not through the slots. This test is intended for the inexperienced riders who may not have previously ridden dressage tests. Riders are not required to demonstrate knowledge of posting diagonals. Riders are required to demonstrate evidence of developing balance (not on reins/mouth), positive control, generally staying on the required track and exhibiting a positive attitude. All trots should be rising except during down transitions. Judging remarks should be very simple and generous with praise. General Impression marks are focused on the riders' ability to control the pony.

2. Starter

To demonstrate that the pony is moving forward, has established a more consistent rhythm and suppleness is beginning to develop. Ponies may be ridden in a simple snaffle or a kimberwick bit with the reins through the ring and not through the slots. Riders should be focused more on accurate riding of the required track, with a balanced, steady seat and sympathetic hands, beginning to develop appropriate contact and are expected to know their posting diagonals. General Impression marks are focused on the riders' ability to influence the pony's performance.

3. Pre-Training

To demonstrate that the pony is moving forward in a steady rhythm, with increased evidence of suppleness, and beginning to accept contact. Riders at this level should be able to deliver an accurate ride, while demonstrating a more effective seat and increased connection from leg to hand. Collective Marks are focused on the performance of the pony/horse.

4. Training

To confirm that the horse's muscles are supple and loose, and that it moves freely forward in clear and steady rhythm, accepting contact with the bit. Rider should be able to apply the correct aids in order to achieve an accurate test with good transitions, demonstrating the ability to ride the horse forward from the leg to the hand.

5. First Level

To confirm that the horse, in addition to the requirements of Training Level, has developed thrust (pushing power) and achieved a degree of balance and thoroughness. Riders should produce a balanced and effective seat that is deep in the saddle with the legs well under the rider and on the horse, enabling them to create a steady, rhythmic gait, with adequate



CANADIAN PONY CLUB

NATIONAL DRESSAGE RULES

2021

Loyalty

Character

Sportsmanship

suppleness to allow maintenance of tempo and balance throughout the movements. Riders should be able to accomplish a sitting trot of such a quality that it results in active engagement of the hindquarters.

6. Second Level

To confirm that the horse, having demonstrated that it has achieved the thrust (pushing power) required in First Level, now shows that through additional training it accepts more weight on the hind quarters (collection), shows the thrust required at medium paces and is reliably on the bit. A greater degree of straightness, bending suppleness, thoroughness and self-carriage is required than at First Level.

7. Third Level

To confirm that the horse, having achieved the requirements of Second Level, now demonstrates in each movement, especially in medium and extended paces and in the transition to and from collected movements, rhythm, suppleness, acceptance of the bit, thoroughness, impulsion, straightness and collection. There must be a clear distinction between the paces.

8. Fourth Level

To confirm that the horse, having achieved the requirements of Third Level, is now able to perform tests of medium difficulty designed to confirm that the horse has acquired a high degree of suppleness, impulsion, thoroughness, balance and lightness while always remaining reliably on the bit, and that its movements are straight, energetic and cadenced with the transitions precise and smooth.

Full descriptions of required movements may be found in the FEI Rulebook

Articles 401 to 418 (www.horsesport.org)



CANADIAN PONY CLUB

NATIONAL DRESSAGE RULES

2021

Loyalty

Character

Sportsmanship

FEI LEVELS FOR DEVELOPING RIDERS

There are six FEI (Fédération d'Équestre Internationale) levels, of which the first four are for the developing rider. It is the intent of the Canadian Pony Club to support riders in achieving these four levels and to encourage the formation of appropriate CPC teams to represent CPC in team competition.

1. FEI Pony

A rider may compete in FEI Pony on a measured pony (148 cm barefoot, 149 cm in shoes) from the beginning of the calendar year in which he/she reaches the age of 12 until the end of the year in which he/she reaches the age of 16. These riders may ride in FEI Pony and either First or Second Level. Tests available are FEI Pony Preliminary, Team and Individual as well as Freestyle (5 min) and are available from the EC office. FEI passports are not required for National competition at this level.

2. FEI Children

A rider may compete in FEI Children on a horse from the beginning of the calendar year in which he/she reaches the age of 12 until the end of the year in which he/she reaches the age of 14. These riders may ride in FEI Children and Second Level. Tests available are FEI Children Preliminary, Team and Individual as well as Freestyle (5 min) and are available from the EC office. FEI passports are not required for National competition at this level.

3. FEI Junior

A rider may compete in FEI Junior from the beginning of the calendar year in which he/she reaches the age of 14 until the end of the year in which he/she reaches the age of 18. These riders may ride in FEI Junior and either Second or Third Level. Tests available are FEI Junior Preliminary, Team and Individual as well as Freestyle (5 min) and are available from the EC office. FEI passports are required for National competition at this level.

4. FEI Young Rider

A rider may compete in FEI Young Rider from the beginning of the calendar year in which he/she reaches the age of 16 until the end of the year in which he/she reaches the age of 21. These riders may ride in FEI Young Rider and either Fourth Level or Prix St. Georges. Tests available are FEI Young Rider Preliminary, Team and Individual as well as Freestyle (5 min) and are available from the EC office. FEI passports are required for National competition at this level.

The final two FEI levels are for the advanced horse and rider.

1. FEI Advanced



CANADIAN PONY CLUB

NATIONAL DRESSAGE RULES

2021

Loyalty

Character

Sportsmanship

FEI Advanced is an open level consisting of Prix St. Georges, Intermediare 1. Tests are available from the EC office.

2. FEI Grand Prix

FEI Grand Prix is an open level consisting of Intermediare 2, Grand Prix and Grand Prix Spéciale. Tests are available from the EC office.

Further information may be found in the FEI rulebook.



CANADIAN PONY CLUB

NATIONAL DRESSAGE RULES

2021

Loyalty

Character

Sportsmanship

GUIDELINES GOVERNING CPC DRESSAGE COMPETITIONS

1 INTRODUCTION

Canadian Pony Club (CPC) Dressage competitions are to be run in accordance with the **CPC Dressage Rules and the CPC General Rules Supplemental**.

The Equestrian Canada (EC) rulebook applies only to the use of Equestrian Canada officials, permits and tests.

All questions other than those pertaining to Equestrian Canada officials, tests and permits are to be referred to the CPC Dressage Rulebook.

In the event that the particular question is not explicitly answered, show organizers may refer the question to their Regional Dressage Chair or National Dressage Chair for clarification. All competitors and organizers should have copies of the CPC Dressage Rulebook made available to them.

All CPC Dressage competitions shall comply with the:

- **CPC Code of Ethics**
- **CPC Code of Conduct**
- **CPC Harassment Policy**
- **CPC Disciplinary Policy**
- **CPC Risk Management Guide**

- 1.1 All Branches and Regional Dressage Chairs should be familiar with the above CPC rules and policies and should have copies available for the use of members, parents, volunteers and officials. Regions may expand upon the National Dressage Rules but may not contradict it, particularly with regards to safety requirements.
- 1.2 Dressage tests may be sourced from the following organizations: CPC, EC and Cadora.
- 1.3 Current CPC Entry, Starter, Pre-training tests and score sheets as well as the freestyle, pas de deux and drill team score sheets may be downloaded from the CPC website (www.canadianponyclub.org).
- 1.4 Cadora tests from Training to Fourth levels are available on the Cadora website (www.cadora.ca).
- 1.5 Current EC dressage tests from Training to Fourth level as well as all the FEI levels are available from the EC office at 2685 Queensview Dr, Ottawa, Ont. K2B 8K2 or may be downloaded from the Equestrian Canada website (<https://www.equestrian.ca/sport/dressage/tests>).



CANADIAN PONY CLUB

NATIONAL DRESSAGE RULES

2021

Loyalty

Character

Sportsmanship

- 1.6 All CPC Branch, Regional & National competitions are restricted to CPC members in good standing with CPC and their Provincial Equestrian Federation or Horse Council (PSO). CPC competitions have access to EC recorded and Basic dressage judges regardless of tests used and do not require a competition permit from EC or PSO.
- 1.7 Branches or Regions hosting open shows for fundraising purposes are covered by CPC insurance, but are not Pony Club only competitions and are required to obtain an Equestrian Canada permit and comply with all EC rules. Provincially sanctioned shows are also permitted provided everyone has PSO membership, all non-members sign the Pony Club non-member risk form and the show is properly documented in your minutes and sanctioned by the Region.
- 1.8 Use of EC tests no longer requires a Discovery permit acquired from the appropriate PSO. Should an EC permit be required, EC permits require the Show Organizer/Manager and the Show Steward to be senior members in good standing of their PSO. EC permits require all horse owners to be members in good standing with their PSO.
- 1.9 All FEI classes operate under FEI rules. FEI rules and tests are copyrighted but are available for use. There is no restriction in the EC dressage rulebook (Section E) regarding their use. Refer to the FEI website for details (www.horsesport.org). Any EC judge officiating at a CPC Dressage Event will not be reprimanded by EC for judging FEI tests. The FEI tests are not submitted to the FEI.
- 1.10 It is the responsibility of Show Organizers/Managers to ensure that all officials hired for the competition clearly understand the CPC Dressage Rulebook, the CPC General Rules Supplemental and that the EC rulebook is not applicable at any time except for the use of EC assets (hiring of officials, the requirement for permits and the use of EC tests). The current EC Rulebooks are available on the Equestrian Canada website (<https://www.equestrian.ca>).



CANADIAN PONY CLUB

NATIONAL DRESSAGE RULES

2021

Loyalty

Character

Sportsmanship

2 CPC NATIONAL DRESSAGE CHAMPIONSHIP COMPETITION

** In the event that the National Dressage Championship is run as a Virtual Competition (i.e. during travel restrictions), revisions may be allowed as outlined below. Approval to run the competition as a virtual competition, must be approved by the National Dressage Chair prior to announcing the competition details to the other regions.

- 2.1 The CPC National Dressage Championships shall be held at each of the following levels as required by member participation:

Training, First

**Restricted levels (as per above) commenced in 2015 but the hosting region may choose to offer higher levels (Second, Third and Fourth or FEI Levels) at their discretion. Should the hosting region choose to do this, significant notice must be provided to all Regional Dressage Chairs in order that they may communicate this to their competitors prior to their qualifying event.

- 2.2 Regions are entitled to send one representative to each level of these Championships. The host region is entitled to qualify a further two members to their respective Championships. CPC National Dressage Champion and Reserve Champion shall be named from this competition. The Host Region may also choose to open up the National Dressage Competition to Horsemasters. In the event that Horsemasters are competing, they must be judged in their own overall category using the sliding scale in this document to apply to the overall score.

** Hosting region may allow for more than 1 competitor to be sent by each region (for example in virtual dressage competitions or where prior year National Dressage competitions were cancelled). In the event that this occurs, all regions must be given the same opportunity for sending additional members.

THE HOST REGION MAY CHOOSE WHETHER TO USE EC OR CADORA TESTS AT TRAINING LEVEL THROUGH TO FOURTH LEVEL.

- 2.3 In addition, the CPC National Dressage Championships may include any of the following levels:

Drill teams at Training, Preliminary, Intermediate and Advanced levels

Pas de Deux at Pre-training Levels

- 2.4 Drill teams and Pas de Deux teams are required to participate in their respective Regional Finals. Videotapes or DVD's of their performance at these Regional Finals may be entered to the National Dressage Chair who shall strike an appropriate panel to judge all entries. CPC National Drill Team and Pas de Deux Champion and Reserve Champion shall be named from this competition.



CANADIAN PONY CLUB

NATIONAL DRESSAGE RULES

2021

Loyalty

Character

Sportsmanship

2.5 The following tests shall be offered at the CPC National Dressage Championships.

Training Level Tests 1, 2 & 3 (EC) or Tests A, B & C (Cadora) Stable Management

First Level Tests 1, 2 & 3 (EC) or Tests A, B & C (Cadora) Stable Management

** Hosting region may decide to offer levels higher than the above and that may include FEI levels in addition to the above levels. In the case that those levels are offered, the following tests would be used for standard EC levels:

Second Level Tests 1, 2 & 3 (EC) or Tests A, B & C (Cadora)

Third Level Tests 1, 2 & 3 (EC) or Tests A, B & C (Cadora)

Fourth Level Tests 1, 2 & 3 (EC) or Tests A, B & C (Cadora)

2.6 Suggested schedule for the National Dressage Championships (in-person event) is as follows:

Thursday: Arrival of competitors

Friday morning: Competitors draw their horse and participate in a lesson / clinic with a respected clinician. ** Horse Selection Committee must attend.

Friday evening: Social event.

Saturday morning: Presentation of first technical test horse for turnout
Completion of first technical test on horse drawn.

Saturday afternoon: Completion of second technical test on horse drawn

Sunday morning: Completion of third technical test on the horse drawn.

Sunday afternoon: Judging of Stable Management.

Awarding of results.

2.7 The CPC National Dressage Championships are under the management of the host region (as is any Regional Final). It is the responsibility of the host Regional Committee to strike a committee and delegate an appropriate Show Manager. The Regional Committee and Show Manager are responsible for the safety and well-being of CPC members as well as the integrity and fiscal health of the Canadian Pony Club as an organization.

2.8 In the event of cancellation of a National Dressage Championship the National Dressage Chair must be advised in advance. The National Dressage Chair, upon consultation with the National Dressage Committee, National Discipline Chair and National Board of Directors, has the authority to delegate another Region to host the competition.



CANADIAN PONY CLUB

NATIONAL DRESSAGE RULES

2021

Loyalty

Character

Sportsmanship

2.9 The following CPC National Dressage Championships are rules that apply to each competitor:

**** NOTE: Stable Management and Turnout may be omitted in a Virtual Dressage Competition or altered to submit specific details via video entries.**

- A. The CPC National Dressage Championships will consist of three technical tests and stable management. All four tests must be entered. The host region may choose the source of tests at Training level and above (EC or Cadora). It is preferable to have each rider draw two different horses. In this case, they would ride the first and third technical test on the first horse drawn and the second technical test on the second horse drawn. The host region may choose to offer only 1 horse draw per rider due to lack of available horses in their area or preference due to horse lenders in that region. This must be well documented ahead of time and the competition must be run in entirety with either one horse drawn or two horses drawn.
- B. Tests may not be called.
- C. The official show tack check shall be BEFORE the class is entered.
- D. The 20x60 ring shall be used at Training level and above.
- E. Any competitor receiving a score less than 40% shall be eliminated from the class. Any score less than 50% on any technical test is not eligible for the class placing or awards. Scores over 40% but less than 50% may be counted towards the National Dressage Championship overall.

2.10 Scoring – The following are the guidelines for scoring the competitors at the National Dressage Championships:

- A. At the National Dressage Championship, the overall National Dressage Champion shall be the highest total score over all technical tests, and stable management as well as the rider portion of the turnout. The overall National Dressage Reserve Champion shall be the second highest total score over all technical tests, and stable management and the rider portion of the turnout. The host region may choose in addition to award the technical Champion and Reserve Champion, using highest and second highest total scores respectively from the two technical tests.
- B. The scoring per division is as follows:

First Technical Test	30%
Second Technical Test	30%
Third Technical Test	20%
Stable Management	10%



CANADIAN PONY CLUB

NATIONAL DRESSAGE RULES

2021

Loyalty

Character

Sportsmanship

Turnout (Rider)

10%

**** In the event of a Virtual National Dressage competition, the turnout and stable management may be eliminated. In that event, each omission will not factor that percentage into overall scoring.**

- C. Grooms will be awarded the points for the turnout of the horse using the National Dressage Groom Turnout sheet provided. The total amount of the score is 100 points. A separate groom's award will be presented based on this scoring. Grooms may also be awarded points during the Stable Management phase of the competition. Entry in the Grooms competition is limited to CPC Grooms only.

- 2.11 Please refer to the Stable Management / Groom Handbook for the Turnout scoring sheets. These are also available on the CPC Web site. One is for the presentation of the Horse (Groom / Horse Turnout Rubric) and the other is for the presentation of the Rider (Rider Turnout Rubric).

Each box is to be marked out of a potential 10 points.

Verbal definition of the score is as per CPC testing (sufficient = 6.5). The representation of that scoring is at the discretion of the turnout judge and is final.

To ensure fairness, the same judge must mark any one entire class.

Any box marked with (x2) is a coefficient, which must be taken into account.

The sub total is calculated out of the total possible 100 points.

A perfect turnout of 100 will suffice to separate two competitors who are very close in their technical score (whether using test % scores or the sliding scale) but is not enough to place a technically poor rider over a technically correct rider. A technically poor rider would represent a difference of 5% between the averages of the technical tests between both riders.

- 2.12 Grooms used at any CPC National competition are restricted to CPC members in good standing with CPC and their Provincial Equestrian Federation or Horse Council (PSO). In the event that not enough CPC grooms are available or where the horse owner would like to supervise the grooming, use of non-CPC grooms will be permitted providing they have a valid current Provincial Equestrian Federation or Horse Council membership. Non-CPC grooms will not be entered in the Grooms competition.



CANADIAN PONY CLUB

NATIONAL DRESSAGE RULES

2021

Loyalty

Character

Sportsmanship

- 2.13 Coaching is not permitted by parents, chaperones or anyone outside of grooms or participating riders. It is recommended that a Youth Rep Committee be developed with at least 2 Senior Pony Club members and possibly one chef d'équipe to head the team. The Chef d'équipe can be a high-profile rider / ex-pony club member. It is also recommended that if the region is running the competition with only 1 horse drawn / competitor that a clinic or instructed lessons are provided before the competition with a qualified instructor.
- 2.14 Each team shall elect a captain amongst the competitors for their region to represent the other competitors to the Ground Jury should any concern or issues arise. Only the Team Captain can go into the Show Office, approach the ground jury or discuss any concerns or issues related to themselves or their team members. The Team Captain can rely on the Chef d'équipe / Coach Mentor if they need assistance approaching the ground jury or for any other advice.
- 2.15 No competitor, chaperone, parent, visitor or anyone not on the Ground Jury shall approach any official at the National Dressage Competition. Violation of this rule can be cause for elimination from the show grounds and potentially from the competition. Unsportsmanlike conduct, inappropriate behaviour or any violation of the code of conduct policy will result in a penalty of 25% to the individual's score. Should this behaviour be exhibited not by a competitor, the Ground Jury or Show Manager determine a penalty which may include, but is not limited to, requiring the individual to leave the show grounds. Where the individual in question has formal responsibility for the competitor(s) e.g. a chaperone, they may not be asked to leave but the team for which that individual is responsible may be assessed a 25% penalty to their score.
- 2.16 All correspondence between the hosting region and the regions should be via the Regional Dressage Chairs (or the Regional Chair in their absence). It is their responsibility to gather and submit the First Notice forms, entry forms and fees for both the competitors and chaperones for the National Dressage competition. It is their responsibility to ensure those competitor entries submitted are for competitors that have met both the regional and national qualification criteria and are an active member of the Canadian Pony Club in good standing. Competitor and Chaperone fees are submitted to the region and the region will submit the forms including the Regional Summary form and payment from the region to the hosting region.
- 2.17 Funds are non-refundable except for documented medical circumstances up to the late entry cut-off date at up to 75% of fees. After the late entry cut-off date, no refund will be given.



CANADIAN PONY CLUB

NATIONAL DRESSAGE RULES

2021

Loyalty

Character

Sportsmanship

- 2.18 Horse Match Ride and Warm-up time per horse / rider combination will have a suggested maximum restriction of 30 minutes except for the clinic before the competition. The restricted time should be 1 hour and 15 minutes for the clinic. See the Horse section ([5.3.8](#)) to outline the process of Horse Draw.



CANADIAN PONY CLUB

NATIONAL DRESSAGE RULES

2021

Loyalty

Character

Sportsmanship

3 QUALIFYING FOR CPC NATIONAL DRESSAGE CHAMPIONSHIPS

- 3.1 The ideal progression to the CPC National Dressage Championships would be from Branch qualifier to Regional Final to National Championship. However, it is left to the discretion of each Regional Dressage Committee to determine how to qualify individuals to the CPC National Dressage Championships.
- 3.2 From the moment, a horse and/or rider have arrived on the show grounds of any Branch, Regional Final, or CPC National Dressage Championship, all CPC policies and the CPC Dressage Rules are in force.
- 3.3 While the criterion for qualifying, the competitors is at the Regions discretion, the competitor must have an average of 58% for the two technical tests they are competing at and requesting to qualify for at the National Dressage Championships.
- 3.4 Qualifying candidates to the CPC National Dressage Championships must meet the following criteria:
 - Training level and all levels above are open to all members D1 level and above, 13 years of age and over.

The age must be met as of Jan 1, of the competition year. Minimum Testing requirements must be met as of the due date of the application for the competition. Subsequent successful testing after Jan 1 of the competition year will not affect the qualifications of the competitors unless the minimum criteria were not met as of this date. NOTE: List of entries must be submitted to the National Dressage Chair for verification once the First Notices have been received and again 2 weeks prior to the start of the competition (and subsequently if there are any changes in competitors).
- 3.5 Regions unable to provide a Regional Finals may choose an alternative process for choosing their Representative to the CPC National Dressage Championships.
- 3.6 The selection of a competitor, who has competed at National Dressage in a previous year, should be restricted to the following;
 - a) Level Training to attend Nationals a maximum of one time at this level.
 - b) Levels 1st and above be restricted to attend Nationals a maximum of 2 times at that level.
- 3.7 When selecting the chaperones for your Regional Team when competing at Nationals, the right of first refusal should be offered to the Regional Dressage Chair. This provides the individual with the necessary experience of attending a National Dressage event as well as the opportunity to participate in a Dressage Committee meeting with the other regions.
- 3.8 A rider may not show at a level lower than one in which they have shown at a previous national championship.



CANADIAN PONY CLUB

NATIONAL DRESSAGE RULES

2021

Loyalty

Character

Sportsmanship

4 REGIONAL DRESSAGE CHAMPIONSHIPS

4.1 It is left to the discretion of the Regional Finals as to which of the following Championship rules they choose to apply. Prize lists must clearly state which rules apply.

- A. Tests may not be called. (This rule can apply to all classes or classes run as Championship only)
- B. The official show tack check shall be BEFORE the class is entered.
- C. The 20x40 ring shall be used for Entry, Starter and Pre-training levels.
- D. The 20x60 ring shall be used at Training level and above.
- E. Drill teams have the option of using either the 20x40 or 20x60 ring as offered by their Regional Finals.
- F. Any competitor receiving a score less than 40% shall be eliminated from the class. Any score less than 50% on any technical test is not eligible for the class placing or awards.

4.2 In order for a Regional Finals to offer regional division championships it must offer two technical tests in that division. It is recommended that two different judges score the two tests. Although no score under 50% may be considered, the Regions do have three options in determining division champions:

- A. Following the above Championship requirement (Section 2.11.A) for technical Champion and Reserve;
- B. Choosing that a minimum score of 60% in one of the two mandatory technical tests be required in order to be named Champion, and a minimum score of 58% in one of the two mandatory technical tests be required in order to be named Reserve Champion;
- C. Choosing to require an average score over 58% in the two technical tests to be named Champion and an average score over 56% to be named Reserve Champion.

The chosen option must be clearly stated in the competition prize list. Should an option not be declared in the prize list, the default option is that of the National Dressage Championships as in Section [2.11.A](#)

4.3 Regional Finals have the option of including any classes they choose, including Freestyles. In order to name a Freestyle Champion a technical test must be ridden in addition to the freestyle. Naming a Freestyle Champion at the Regional Finals is optional as Regions may choose to allow an entry into the freestyle alone.



CANADIAN PONY CLUB

NATIONAL DRESSAGE RULES

2021

Loyalty

Character

Sportsmanship

- 4.4 CPC Freestyle tests are available for Starter and Pre-training levels on the CPC website. Cadora has a Freestyle test at the Training level. Both Cadora and EC have Freestyle tests available at First Level and above. Cadora tests are available on the Cadora website (www.cadora.ca). The EC tests are available on the Equestrian Canada website (<https://www.equestrian.ca/sport/dressage/tests>).
- 4.5 Examples of other optional classes at the Regional Finals include the CPC Drill Teams, the CPC Pas de Deux, Dressage Equitation (usually determined by CPC level), Mystery tests and FEI tests.
- 4.6 Regions MUST have a Safety Officer and a Safety Steward in addition to the official Show Steward. For further information on the responsibilities of all show officials please refer to the list of Show Personnel.
- 4.7 Safety tack check by the Safety Steward is mandatory in the warm up ring.
- 4.8 In order to be considered a championship, the Regional Finals must have the official tack check (for legal tack as per CPC Dressage Rules) by the Show Steward either before or after the class. Regions may choose to have an additional tack check after the class. In the event that the Regions choose to have the official tack check after the class, they must also provide a tack check before the class. Either tack check may disqualify a competitor. The show prize list MUST clearly state when the official tack check is taking place. The show organizers are responsible for clearly informing all competitors of the official tack check.
- 4.9 Having received the tack check, the competitor may not leave the vicinity of the Show Steward before entering the class. Should a competitor leave the vicinity or the warm up area, they must represent themselves to both the Safety Steward and Show Steward for another check.
- 4.10 Regions have the option of having one individual act as both the Safety Steward and the Show Steward.
- 4.11 At Regional Finals a horse/rider combination may enter a maximum of two consecutive levels/divisions and one Freestyle as well as any Pas de Deux, Drill Team or Equitation class.
- 4.12 At Regional Finals, one horse may be ridden by two riders, but may not cross over levels/divisions with one rider. (i.e. rider A rides at the lower level, rider B rides one level higher). Only one rider may ride the Freestyle, at the technical level of that rider.
- 4.13 Should there be only one entry in any class, placings shall be awarded in accordance with the score achieved.



CANADIAN PONY CLUB

NATIONAL DRESSAGE RULES

2021

Loyalty

Character

Sportsmanship

- 4.14 Competition may be offered for both individuals and teams at the “D”, “C”, “A/B” or combined levels at the discretion of the Regions. Teams should consist of either three or four riders with the highest two or three scores to count.
- 4.15 The Team Competition Sliding Scale shall be used for the determination of Team Champions and individual D, C and A/B Champions. This scale may also be used for scoring Horsemasters competing at Regional or National competitions in differing levels.

Test %	Entry	Starter	Pre-training	Training	First Level	Second Level	Third level	Fourth Level
70% +	14	15	16	18	20	23	27	30
68-69.99%	12	13	14	16	18	21	25	28
66-67.99%	10	11	12	14	16	19	23	26
64-65.99%	8	9	10	12	15	18	21	24
62-63.99%	7	8	9	11	14	16	19	22
60-61.99%	6	7	8	10	13	15	18	20
58-59.99%	5	6	7	8	12	14	17	18
56-57.99%	4	5	6	7	11	13	16	17
54-55.99%	3	4	5	6	10	12	15	16
52-53.99%	2	3	4	5	9	11	14	15
50-51.99%	1	2	3	4	8	10	13	14

- 4.16 A turnout score sheet is provided at the end of the organizers’ handbook (see Regional Score Sheet), after the test score sheets.

Each box is to be marked out of a potential 10 points. Verbal definition of the score is as per CPC testing (sufficient = 6.5). The representation of that scoring is at the discretion of the turnout judge and is final.

To ensure fairness, the same judge must mark any one entire class.

Four boxes have a coefficient of x2, which must be taken into account.

The sub total is calculated out of the total possible 200 points.

Simple division by 100 yields a mark out of 2.00.

Example: sub total of 152 out of 200 yields a final total of 1.52 out of 2.00

A perfect turnout of 2.00 will suffice to separate two competitors who are very close in their technical score (whether using test % scores or the sliding scale) but is not enough to place a technically poor rider over a technically correct rider. A technically poor rider



CANADIAN PONY CLUB

NATIONAL DRESSAGE RULES

2021

Loyalty

Character

Sportsmanship

would represent a difference of 5% between the averages of the technical tests between both riders.

- 4.17 Should the Show Manager withdraw or be unable to fulfil the duties as delegated by the host committee, the Regional Committee Chair has the authority to delegate the position to another individual after consultation with the Regional Committee.
- 4.18 The Regional Dressage Chair has the authority to cancel a competition for any number of reasons (weather, finances, and lack of entries). Cancellation must be announced a minimum of 48 hours before the scheduled start of competition. The Regional Committee, all officials and registered competitors must be contacted immediately. With the exception of unforeseeable emergencies, the Provincial Equestrian Federation or Horse Council, which had issued the competition permit must be informed in advance. It is prudent to post the cancellation upon the relevant web sites as quickly as possible.
- 4.19 The Regional Committee is the only body with the authority to reschedule a Regional competition or enter into a contract with officials and facilities.



CANADIAN PONY CLUB

NATIONAL DRESSAGE RULES

2021

Loyalty

Character

Sportsmanship

5 CANADIAN PONY CLUB DRESSAGE COMPETITION RULES

5.1 INTRODUCTION

- 5.1.1 CPC Dressage Rules apply from the moment a horse and/or competitor arrive on the show grounds of a Branch, Regional Final or CPC National Dressage Championship.
- 5.1.2 In all instances that a ruling cannot be found in the CPC Dressage Rules or the CPC General Rules Supplemental, the ruling of the competition Ground Jury shall prevail. Should a dispute take place, the CPC has in place a dispute resolution process. No other organization has any authority in the disposition of disputes.
- 5.1.3 All competitors, officials and volunteers must understand that they are to support the CPC Dressage Rules, all CPC Policies and the CPC Code of Ethics at all times.
- 5.1.4 The CPC Dressage Rules and all CPC Policies apply to all competitors, horse owners and spectators regardless of their membership in CPC.
- 5.1.5 Equestrian Canada rules are to be followed only with regard to the use of Equestrian Canada assets such as EC dressage tests, EC officials and EC permits.
- 5.1.6 FEI rules are to be followed only as applicable to FEI classes should they be offered.

5.2 COMPETITORS

- 5.2.1 Competitors at CPC National Dressage Championships must be current CPC members in good standing nominated by their Region. National Dressage Championships may not offer any other classes towards the Championship.
- 5.2.2 Competitors at CPC Regional Dressage Finals must be current CPC members in good standing who have qualified in accordance to their Regional qualifying procedures.
- 5.2.3 Competitors at CPC Branch Dressage competitions must be current CPC members in good standing to be eligible for classes qualifying to Regional Finals.
- 5.2.4 Branch shows may no longer offer open classes in which non-CPC members compete. Branches wishing to operate open shows may do so only as a fundraiser (CPC insurance requirements) under an EC licence. All competitors and horse owners, whether CPC members or not, must comply with requirements of EC. Non-CPC-member acceptance of risks forms must be used.
- 5.2.5 Non-CPC-member competitors in such open shows must comply with all CPC rules, procedures, policies and Code of Ethics. Any competitor may be disqualified from the competition if found to contravene the CPC Code of Conduct or Code of Ethics.
- 5.2.6 Any rider of any age, whether a CPC member or not, may be barred from mounting a horse should their helmet be found to not meet the required standard.
- 5.2.7 Any riders of any age, whether a CPC member or not, may be disqualified from CPC competitions or open shows in accordance to the CPC Dressage Rules or any relevant CPC Policies and asked to leave the show grounds.



CANADIAN PONY CLUB

NATIONAL DRESSAGE RULES

2021

Loyalty

Character

Sportsmanship

5.3 HORSES

- 5.3.1 Owners of horses borrowed by CPC for the purpose of a CPC National Dressage Championship must be members of their Provincial Equestrian Federation or Horse Council. Organizers are permitted to offer to pay for such membership in order to ensure the availability of the horse. Any horse not covered by their respective owner's membership is not allowed on the grounds of a CPC competition or activity.
- 5.3.2 An individual CPC member may at any time make a private arrangement to borrow or lease a horse from an acquaintance or business. It is highly recommended that the owner of such a horse be a member of their Provincial Equestrian Federation or Horse Council and CPC members are encouraged to supply this membership to such a generous owner.
- 5.3.3 At any CPC activity, should an official veterinarian be present, he/she has the authority to deem a horse to be unfit for competition due to illness, soundness or lack of fitness upon presentation. Such a ruling is not open to debate and will stand.
- 5.3.4 Any horse at a CPC Dressage competition may be prevented from competing should their equipment be deemed to be unsafe, ill-fitting or causing pain and suffering to the horse. Should a dispute arise it is to be presented to the Ground Jury.
- 5.3.5 Any horse entered in a CPC dressage competition must be a minimum of Five (5) years old, and if supplied to the National Dressage Championships must have experience at the level of competition. It is recommended that the Hosting Region validate their experience and appropriateness for the use at a National Competition.
- 5.3.6 Only the assigned competitor may school the horse on the show grounds of the CPC National Dressage Championships. With the exception of the designated rider for the Demonstration part of the Horse Matching at the National Competition. A mounted groom/owner may walk the horse on a long rein. The horse may be lunged by someone other than the competitor under the supervision of a competition official as designated by the Show Organizer.
- 5.3.7 Horses and equipment are to be clean and neat out of respect for officials, volunteers and other competitors. Manes are to be neat and tidy, either roached or braided in an attractive manner. Manes may be kept long in accordance with breed requirements but should be restrained in an attractive manner, which will allow the judge to observe the horse without distraction.
- 5.3.8 Riders may not ride their own horse at National competitions. In a National competition, the horses must be blindly drawn by the competitor from a pool of adequate and provided horses. Horse assignment or matching is not allowed. Upon recommendation of the Horse Selection committee, when the rider wishes to choose another horse other than the one selected for them, a penalty will be applied. See Section 6.2.11 for penalty assignment.



CANADIAN PONY CLUB

NATIONAL DRESSAGE RULES

2021

Loyalty

Character

Sportsmanship

5.3.9 Other than for the horse's safety or when a horse is removed from that competitor's level or from the competition all together for lameness or safety reasons, this rule will apply.

5.4 DRESS

5.4.1 Lack of a CPC crest on the jacket will be penalized only in the turnout category.

5.4.2 Judges may excuse jackets in extreme heat or humidity. Appropriate notice must be given so that all competitors in any one class ride under the same conditions. Competitors have the option of wearing either short or long-sleeved shirts with a collar (no T-shirts, tank tops etc.) that tuck neatly into the breeches. A cooling or tailored dressage vest may be worn over a long or short sleeved riding shirt. The vest colour must confirm to the rules for jacket colours. At the CPC National Dressage Championships, the shirt must be white. Chokers may be worn with ratcatchers. Stock ties and ties must be removed. Regulation helmet is still required.

5.4.3 Regional or Club events may excuse jackets in costume classes (i.e. pas de deux, quadrilles, freestyle / kur, etc.)

5.5 SADDLERY AND EQUIPMENT

5.5.1 At the CPC National Dressage Championships saddle pads must be plain white or black, not coloured, and may carry the branch/regional logo or trim colours. At Regional/Branch competitions pads may be any neutral or conservative solid colour and may carry the branch/regional logo or trim colours.

5.5.2 PROTECTIVE GEAR

Lunging equipment (on unmounted horses only) are permitted only in designated lunging areas.

Non-restrictive ear net, which do not cover the eyes and non-restrictive nose fly guards are permitted in the schooling and competition rings.

Show Stewards are entitled to request the removal of protective boots and bandages as well as ear nets, and nose fly guards as part of the compulsory tack check.

6 EXECUTION AND JUDGING OF TESTS

6.1 EXECUTION

6.1.1 Other than at the CPC National Dressage Championships and any Regional Final declaring itself to run under Championship rules, competitors may arrange for a suitably (conservatively) dressed individual to call or read the test.



CANADIAN PONY CLUB

NATIONAL DRESSAGE RULES

2021

Loyalty

Character

Sportsmanship

- 6.1.2 Competitors are responsible for any error made by the designated reader of the test. Any command or instruction which is repeated more than once (i.e. read three times) or which is embellished in any way to assist the competitor will cause the elimination of the competitor. Designated readers are to be placed in such a way that they do not disturb nor obstruct the view of the judge(s).
- 6.1.3 **EXCEPTION:** Should a CPC member not have a working knowledge of English, it is their responsibility to inform CPC of the requirement for CPC tests in French. It is the responsibility of the competitor to request the French version of EC tests from Equestrian Canada. CPC is not responsible for any material which does not belong to CPC. CPC is not required to facilitate translation for non-CPC members.
- 6.1.4 Unauthorized assistance is deemed to be any external influence such as the use of voice, signals or electronic transmission which is intended to assist the competitor upon entering the competition arena. Such assistance is cause for elimination.
- 6.1.5 All FEI tests and all freestyle tests are to be executed from memory.
- 6.1.6 All technical tests are timed from the time of entry into the ring.
- 6.1.7 The salute is to be performed with the rein in any one hand. Helmets are not to be removed. The arm is to be dropped in a relaxed manner along the body and the head inclined towards the senior judge at C.

6.2 **ERRORS AND PENALTIES**

- 6.2.1 Should a competitor use the voice in any manner (including tongue or throat sounds) the penalty is considered to be an error of voice which is awarded a penalty of two points for each occurrence. There is no maximum limit to errors of voice, nor is it limited to once per movement.
- 6.2.2 An error of course is considered to be an error in the execution of the test, which prohibits the rider from continuing on with the next movement (i.e. turning in the incorrect direction or omitting an entire movement). At such time the Judge at C shall ring the bell in order to lend the competitor the assistance necessary to return to the correct course.
- The first such error is penalized by two points. The second such error is penalized with 4 points. The third such error is cause for elimination, although competitors are permitted to finish their tests and further movements are marked.
- 6.2.3 An error of course which does not require the bell to be rung is one in which interrupting the test will have a negative effect on the flow of the test since the rider is able to continue the test without impediment (i.e. transition takes place at the wrong letter). The penalties are the same as shown above in Section 6.1.2.



CANADIAN PONY CLUB

NATIONAL DRESSAGE RULES

2021

Loyalty

Character

Sportsmanship

- 6.2.4 Should a competitor not complete a required movement (i.e. rising when sitting required, missed a circle), the bell is not required as the flow of the test should not be interrupted and the movement is marked as an error of test. The penalties for an error of test are the same as that for error of course.
- 6.2.5 Should there be multiple repetitions of the same error of test in a movement only the first error is penalized. The others are noted as comments.
- 6.2.6 Should a competitor choose to repeat a movement without the permission of the Judge, the first effort only is marked and an error of test is incurred.
- 6.2.7 Should the Judge not observe the error then the competitor is given the benefit of the doubt.
- 6.2.8 Should the Judge at C not observe the error, the panel may bring it to the attention of the other members and the judge at C shall determine whether the error shall be incurred.
- 6.2.9 Entry into the ring before the designated signal has been sounded by the Judge the entry mark shall show a penalty of 2 marks. The Judge may choose to ask the competitor to exit and re-enter the ring.
- 6.2.10 Under unusual circumstances, which may interfere with the test, the Judge may stop the test and allow the competitor to restart.
- 6.2.11 Any elimination of a rider must be brought to the Stewards attention for verification with current rules, both EC and Pony Club before becoming final.
- 6.2.12 Penalties of 25% of the overall score will be applied in the case of code misconduct by the competitor and/or chaperone (as per section 2.19) or in the case of rider requested mount change (as per Section 5.3.8).

6.3 LAMENESS

- 6.3.1 It is the responsibility of the Judge to call attention to any case of lameness which shall include marked unevenness and/or irregularity in which case the Judge may ring the bell and eliminate the competitor.
- 6.3.2 The decision of the Judge may not be appealed. Judges are circumspect with regards to making such a critical decision and unless absolutely certain will tend to give low marks rather than eliminate. This difficult decision must be respected.
- 6.3.3 The official Veterinarian for the competition may be called upon by the Organizing Committee or Ground Jury in order to determine if a horse is to be declared unsound for competition. The decision of the official Veterinarian is not open to appeal.
- 6.3.4 Any individual who feels that a horse (other than their own) is unsound and wishes to see it pulled out of competition may report to the official Show Steward. The Show Steward may speak to the competitor in question if there seems to be evidence of lameness or may require the submission of an official protest.



CANADIAN PONY CLUB

NATIONAL DRESSAGE RULES

2021

Loyalty

Character

Sportsmanship

6.4 FALLS AND DISMOUNTS

- 6.4.1 A fall by the rider is considered to have taken place when the rider is separated from the horse in such a manner that he/she must remount the horse in order to regain contact with the saddle.
- 6.4.2 A fall by the horse is considered to have taken place if both the shoulder and quarters of the horse have touched the ground simultaneously.
- 6.4.3 A fall of horse and/or rider in the competition ring will result in the immediate elimination from the class. All falls must be reported immediately to the Safety Officer and the required paperwork must be submitted to the CPC National Office.
- 6.4.4 A rider who has chosen to dismount during a movement of the test without the permission of the Judge will not receive a mark for that movement but may continue with the test if the Judge determines the reason acceptable and subsequently gives permission for the test to continue.
- 6.4.5 A competitor who dismounts due to broken equipment and/or loss of a shoe will be excused from the class.

6.5 ELIMINATION AND DISQUALIFICATION

- 6.5.1 An elimination results in no score or result being posted for the class in question due to any of the following: ** Removed failure to enter ring within designated time as this is now resulting in errors not elimination.
- a) any three errors of course or test (excluding mystery tests);
 - a) illegal equipment;
 - b) failure to report to tack check;
 - c) unauthorized assistance;
 - d) resistance lasting longer than 20 sec which prevents the performance of the required movements of the test;
 - e) safety – resistance that may endanger the rider, horse, judge or spectators is cause for elimination at discretion of judge (may be less than 20 seconds);
 - f) leaving the arena with all four feet of the horse during the test;
 - g) lameness;
 - h) fall of horse or rider;
 - i) performing movements above the required level of the freestyle;
 - j) excessive use of the whip;
 - k) receiving a score of less than 40%;
 - l) inappropriate dress;
 - m) evidence of blood or welt marks on the horse other than environmental (bee stings, insect bites)
 - n) dangerous or unruly behaviour of the horse;
 - o) failure to finish the test.



CANADIAN PONY CLUB

NATIONAL DRESSAGE RULES

2021

Loyalty

Character

Sportsmanship

N.B. Any of the grounds for disqualification shown below may also result in elimination from classes already completed. This determination shall be made by the Ground Jury and is not open to appeal.

6.5.2 Disqualification bars the competitor from taking part in any further classes in the competition. The Ground Jury may require the competitor to leave the competition site. Grounds for disqualification include but are not limited to:

- a) failure to display a competition number, having incurred a warning for the first offence;
- b) misrepresentation of eligibility of horse;
- c) misrepresentation of ownership of horse;
- d) misrepresentation of eligibility of rider;
- e) misrepresentation of signatures on entry and liability forms;
- f) failure to provide documentation and/or payment;
- g) cruelty;
- h) excessive discipline of the horse;
- i) failure to comply with the CPC Code of Ethics and Harassment Policy;
- j) offensive behaviour and/or language towards officials, volunteers, competitors, or spectators;
- k) any act which is deemed by the Ground Jury to be unacceptable and does not comply with the standard of behaviour required by CPC.

6.6 FREESTYLES

6.6.1 Timing of freestyles begins with the first stride after the initial salute and ends after the final salute. Both initial and final salute must take place inside the competition ring, facing the judge. No movements prior to the initial salute or after the final salute are considered to be part of the test and will not be marked.

6.6.2 Judging of the freestyle begins with the initial halt and ends with the final halt.

6.6.3 Should there be a disruption of the music, the Judge may give the competitor permission to leave the ring and reschedule the test at the end of the class if there is a scheduled break.

6.6.4 It is the responsibility of the competitor to provide Show Management with their music well ahead of the class in order to provide an opportunity for a sound check.

6.7 JUDGING THE TEST

6.7.1 The responsibility for marking the tests correctly lies with the judges. FEI Article 116 clearly states the responsibility of judges. The objectives and general principles are available in FEI Articles 401 to 418.

6.7.2 Judges may not be influenced by any previously held knowledge or information from any individual other than members of the Ground Jury.



CANADIAN PONY CLUB

NATIONAL DRESSAGE RULES

2021

Loyalty

Character

Sportsmanship

6.7.3 A full complement of volunteers is required to aid the judge in fulfilling their responsibilities and is listed under Officials and Volunteers.

6.8 PERMITS AND TESTS

6.8.1 All CPC competitions (open to CPC members only) have access to EC officials. Dressage shows may use EC recorded and Basic judges regardless of tests used.

6.8.2 All CPC competitions (open to CPC members only) may use CPC tests, and any test from another organization (other than USEF) that has given permission for their use.

PLEASE NOTE that the use of EC tests at Training level and above at a CPC competition (open to CPC members only) DOES NOT require a Discovery permit (to be obtained from the appropriate PSO).

6.8.3 Discovery permit shows have restrictions (refer to EC rulebook E Article 3.0 – competition chart) regarding their duration, levels allowed, etc. Note that with Discovery permit, horse owners as well as riders be members of their PSO.

6.8.4 CPC tests, Cadora tests and FEI tests are available to any who choose to use them with no restriction.

6.8.5 In the absence of EC recorded judges, Regions may employ Learner judges and stewards, or any suitable knowledgeable individual who supports the classical principles as espoused by CPC. Local coaches, officials, and CPC examiners may be able to recommend appropriate individuals.



CANADIAN PONY CLUB

NATIONAL DRESSAGE RULES

2021

Loyalty

Character

Sportsmanship

7 OFFICIALS AND VOLUNTEERS

7.1 OFFICIALS

- 7.1.1 All CPC dressage competitions (open to CPC members only) may acquire the services of EC recorded, Basic or learner judges and stewards, or any knowledgeable individual who supports the policies and principles of CPC.
- 7.1.2 Officials are required to uphold the CPC standard of care and treatment of horses with the kindness, care and compassion that any animal under our care and control deserves. Officials are responsible to ensure that all competitors, owners, handlers and by-standers do not cause undue stress or subject horses to mistreatment, abuse, cruelty or inhumane treatment.
- 7.1.3 The term Show Officials is applied to those individuals who may affect the outcome of a class. Although their job descriptions have been listed under both Officials and Volunteers, the term Show Officials applies to the Judges, Show Organizer/Manager/Chair/President, Show Steward and Show Veterinarian.

7.2 CONFLICT OF INTEREST

- 7.2.1 Officials may not conduct a class in which a competitor is an individual who has been instructed, coached or tutored by them with or without pay within 30 days of the competition.
- 7.2.2 Officials may not conduct a class in which a competitor is their coach, an owner of the official's horse or family member of the horse owner within 30 days of having received instruction.
- 7.2.3 Should a competitor arrive at a competition and discover that an official from whom instruction has been received within the past 30 days is acting on behalf of the show, it is the responsibility of the competitor to declare and remove themselves from any class involved with that official.
- 7.2.4 Officials may not be the houseguest of a competitor or family of a competitor during the course of the competition.
- 7.2.5 Officials may not conduct business relating to the purchase, sale or lease of any horse taking part in a competition during the relevant competition.
- 7.2.6 Officials may not at any time conduct a class in which a member of their family or horse owned by immediate family is taking part. Stewards responsible for checking tack on a member of his/her immediate family is also prohibited.
- 7.2.7 Officials may not at any time conduct a class in which a current (30 days) client or horse owned by a client is participating.
- 7.2.8 Show Veterinarians may find themselves in a position of conflict of interest. As Show Veterinarians are in short supply they are exempt from such charges with respect to clients of their veterinary profession.



CANADIAN PONY CLUB

NATIONAL DRESSAGE RULES

2021

Loyalty

Character

Sportsmanship

7.3 JUDGES

- 7.3.1 No Judge should be expected to judge more than 60 horses/ponies. No Judge shall be required to officiate longer than the eight (8) hours in one day and cannot be required to be on the competition grounds longer than ten (10) hours.
- 7.3.2 Judges must be given 45 minutes (minimum) for a lunch break. A 10-minute break should be given every hour. If this is not possible, a 15-minute break must be given every 2 hours.
- 7.3.3 Judges are to arrive at the competition site 20 minutes in advance of their first class and present themselves to the Organizer in charge dressed in a conservative and respectful fashion.
- 7.3.4 Judges are responsible with the Show Steward for ensuring that the competition ring is correctly set up.
- 7.3.5 Judges are expected to be knowledgeable about the rules and requirements of any class they have agreed to judge.
- 7.3.6 Judges may have a reasonable expectation of privacy. Only the Show Steward or Organizer may approach the Judge to discuss to their results. Judges are not required to give any reasons for their decisions other than those shown on the dressage score sheet.
- 7.3.7 A competitor may make an inquiry through the Show Steward regarding a decision and the Show Steward may request a judge to provide an explanation. Should the competitor not be satisfied with the result of the enquiry, an official protest must be lodged. At no time, may the judge be approached directly.
- 7.3.8 Judges must maintain a degree of safety in the competition ring and may excuse any horse/rider deemed to be unruly, unsafe or a danger to others.
- 7.3.9 It is the responsibility of the Show Management to ensure that Judges are conversant with the CPC Dressage Rules and that the relevant tests are made available well in advance.

7.4 SHOW STEWARDS

- 7.4.1 The purpose of the Show Steward is to ensure a fair competition which respects the CPC principles of character, loyalty and sportsmanship.
- 7.4.2 Stewards fulfil their duty by:
 - a) helping both competitors and show organizers in clearly understanding the rules;
 - b) ensuring optimum conditions for the competition in both the competition and schooling areas;
 - c) upholding the welfare of the horse and acting on all reports of abuse;
 - d) confirming that results and championships are correctly calculated and posted;
 - e) supervising schooling areas;



CANADIAN PONY CLUB

NATIONAL DRESSAGE RULES

2021

Loyalty

Character

Sportsmanship

- f) reporting infractions to the organizing committee or Ground Jury;
 - g) acting as liaison between competitors and officials (with the permission of the judge or veterinarian);
 - h) confirming that CPC rules are upheld;
 - i) confirming that EC rules are upheld regarding eligibility of officials, prize lists and non-CPC members and horse owners where required by the PSO.
- 7.4.3 The Show Steward is responsible for completing the official tack check either prior to or immediately after the competitor has entered or left the competition ring in accordance with the prize list.

At the CPC National Dressage Championships, the official tack check is mandatory BEFORE the class as the competitors are riding unknown horses and are not using their own tack or equipment.

7.5 SHOW VETERINARIAN

- 7.5.1 The Show Veterinarian must commit to being on the competition grounds throughout the duration of the competition. The Show Veterinarian may be a part of the Ground Jury and has the authority to spin horses out for lameness, illness or lack of fitness.
- 7.5.2 The on-call veterinarian is available on an as-needed basis and has committed to being within communication and commuting range for emergencies.

7.6 GROUND JURY

- 7.6.1 Under various circumstances, different groups of officials are responsible for various decisions. For clarity, the Ground Jury shall make all such decisions at CPC Dressage competitions.
- 7.6.2 The Ground Jury shall consist of three individuals chosen from the panel of Judges, the Show Organizer, the Show Steward and the Show Veterinarian. At least one Judge must be a member.
- 7.6.3 The decision of the Ground Jury shall be final and is not open to appeal.
- 7.6.4 The responsibility of the Ground Jury is to deal with protests and disqualifications that fall within the guidelines described in this rulebook.

7.7 VOLUNTEERS

- 7.7.1 Volunteers are the foundation of the CPC. As such they must be treated with respect and consideration at all times. It is to the benefit of all to take the time to offer volunteers accurate job descriptions and adequate training for the task. Many are not familiar with horses.



CANADIAN PONY CLUB

NATIONAL DRESSAGE RULES

2021

Loyalty

Character

Sportsmanship

- 7.7.2 Volunteers often accept great responsibility for the safety of both participants and bystanders. Although CPC members are welcome and encouraged to volunteer at CPC activities any task, which involves matters of Risk Management should be placed in the hands of adults who are in a position to take on not only the responsibility but also the risk involved.
- 7.7.3 Volunteers should be made aware of the existence of CPC policies with respect to Risk Management, the Code of Ethics, Harassment Policy and Procedures for Handling Breaches of the Code of Conduct. Where applicable volunteers should have a reasonable understanding of the CPC Dressage Rules.

7.8 VOLUNTEER JOB DESCRIPTIONS

- 7.8.1 **Show Organizer/Manager/Chair/President** – is responsible for the preparation and distribution of the prize list; arranging for the use of the competition site; engaging all officials; signing contracts; preparing awards; organizing volunteers; scheduling the day; preparing the equipment needed for the competition and too many other details to list. If it has to be done, do it or delegate!
- 7.8.2 **Show Secretary** – is responsible for the acceptance of all entries; confirming eligibility; ensuring all required signatures have been collected; ensuring officials are in place; communicating changes to competitors and officials. This must be one of the most crucial jobs at the show. The person doing this job is the first face of the day for the majority of the competitors and often sets the tone. On the day of the competition the pace is hectic, particularly in the early morning and help in the form of extra (trained) bodies should be made available. For some reason competitors, parents and coaches tend to heap the most abuse on this poor soul. Patience is not only a virtue but a necessity for the job. Logic helps, but only if one realizes that under stress the competitors and parents tend not to be equally logical back. On show day, everyone hates the paperwork and few are willing to acknowledge the necessity for it.
- 7.8.3 **Show Treasurer** – is responsible for the acceptance of all revenue and tracking of expenses and passing on all information to the Regional or Branch Treasurer of the host show.
- 7.8.4 **Safety Officer** – has a specific role as designated and fully described in the CPC Risk Management Guide. This individual is responsible for a safety plan for the facility and competition. The individual tasked with this role may not perform any other role during the day, must be available throughout the competition and may not leave the competition grounds. This precludes the parent or coach of active competitors from performing this role. The job includes preparatory work to be completed before the day of the competition. The goal is to have nothing to do on the actual day of competition as adequate preparation and precautions ensure a very safe environment. The Safety Officer is responsible for all incident reports and witness statements and must fill them out for EVERY incident however minor.



CANADIAN PONY CLUB

NATIONAL DRESSAGE RULES

2021

Loyalty

Character

Sportsmanship

- 7.8.5 **Safety Stewards** – any qualified individual who is responsible for maintaining safe behaviour and checking on safe equipment in the warm-up and schooling areas. The Safety Steward has the responsibility of checking tack for the purpose of safety, not for compliance with respect to the rules of the competition. This individual may require that competitors prove their helmets meet the required standard but **MUST** do so while the competitor is unmounted.
- 7.8.6 **Judges Writers/Scribes** - A knowledgeable individual should perform the job of filling in the tests for the Judge. The person performing this task should familiarize him/herself with the test being performed and be the Judge's assistant during the Show. One individual is required for the entire day for each Judge for the sake of continuity. Scribes should be instructed regarding errors and eliminations. Scribes should refrain from commenting on their personal knowledge of competitors. It is preferable that the scribe not be related to any competitor.
- 7.8.7 **Scorers** - This job is best performed by someone who is able to use a calculator and/or spreadsheet with confidence. Each competition ring requires two individuals to perform this duty so that one can score and the other can confirm and post the final scores for each competitor. It is recommended that at least one calculator should produce a paper record of the scoring to be stapled to the tests. This job may be shared over the course of the day, as it does not require that the same scorers be available throughout the entire day. The scoring area is off limits to riders, parents, and coaches.
- 7.8.8 **Runners** - Individuals are designated to pick up the completed tests from the Judge and deliver the tests to the scorers, minimally after every third ride, preferably after every horse has performed the final salute. Runners may also deliver food, water and messages. In return they have the opportunity to watch the tests and observe the warm up.
- 7.8.9 **Whipper-In** - is **NOT** responsible for ensuring that the competitors are ready and waiting their "time". That responsibility lies with the competitor. However, as a courtesy, the Whipper-in informs the competitors of the official show time and may remind them of their tack check. The Whipper-in informs the Judge of any scratches, and informs the competitors of opportunities to ride early, but does **NOT** require them to do so. The Whipper-In is in charge of the ring should anything need attention. It is their job to find the required help or send a runner to find help.



CANADIAN PONY CLUB

NATIONAL DRESSAGE RULES

2021

Loyalty

Character

Sportsmanship

- 7.8.10 **Gate attendant** – This individual is assigned the job of opening and closing the arena gate for competitors. It is an advantage to appoint two people so that rest periods can be worked in. They should work in conjunction with the Whipper-In and the Show Steward. If no person is available, riders may be expected to provide someone to open and close the gate. The Show Organizer has the option of allowing the gate to remain open at A and not providing a gate attendant. The status of the gate (open or closed) must remain consistent for the class. The CPC National Dressage Championships require the gate to be closed as a safety precaution as competitors are riding unfamiliar horses.
- 7.8.11 **Emergency Medical Personnel** - Care should be taken that Emergency Medical Personnel are appropriately licensed as required by the Risk Management Guide and the Provincial Equestrian Federation or Horse Council which issues any permits. Please note not all such personnel are licensed to travel with a patient, and that should the official show medical personnel leave the grounds the show cannot continue. Furthermore, not all such personnel are licensed to perform these duties outside of their normal employment. Please confirm that your personnel are suitably licensed.
- 7.8.12 **Announcer** - This is a very helpful job and can keep the competition running on time. Complete information should be kept in the hands of this person at all times. It is recommended that the announcer announce the official show time regularly.
- 7.8.13 **Show Farrier** – it is beneficial to have a farrier on the grounds or on call. The Show Organizer is not required to hold up the show should a horse require repair to a shoe. If a farrier is available and the repair done in time, the competitor may be rescheduled at the end of their class. As classes may not be split, competitors have limited time in which to obtain the services of the farrier. The CPC National Dressage Championships require that a farrier be available to ensure that horses may enter their classes. Farriers usually require payment to be on the show grounds but will often agree to be on-call at no fee. Should their services be required they will be charging the competitor directly.
- 7.8.14 **Veterinarian** – A veterinarian should always be available on call or at least be aware of the possibility of a call. Arrangements should be made with a veterinarian who agrees ahead of time to be willing to drive out to the competition site in the case of an emergency. Unlike the official Show Veterinarian, the on-call veterinarian is not required to be on site at all times and is not a member of the Ground Jury.
- 7.8.15 **Stable Management Judge** - Any competent individual familiar with CPC standards of Stable Management may be asked to act as the judge. Branch and Regional dressage competitions have the option of including stable management or turnout. The CPC National Dressage Championships will include turnout and will use the score sheet included in this rulebook.



CANADIAN PONY CLUB

NATIONAL DRESSAGE RULES

2021

Loyalty

Character

Sportsmanship

- 7.8.16 **Computer Whiz** – someone who can work a spreadsheet (programs have been developed for CPC that will calculate the results for all CPC, EC and Cadora tests), can maintain the required master sheet of results (for protests), produce result sheets for posting, and manage a database of entries for reference. Wonderful person to have for scoring.
- 7.8.17 **Stable Management Judge** – must have previous experience judging stable management i.e. Canadian Pony Club Championship Rallies, Regional Rallies, 'A' & 'B' Testing. Dressage Stable Management is judged at a C level so they must be knowledgeable about the requirements for this level. Wherever reasonable, Stable Management Judges should be obtained outside the host Region.
- 7.8.18 **Communications and Media** – A communications person will be designated to provide media releases, take photos and provide information to media and social media. This role is to support the growth of pony club through the encouragement of new members and recognition of successes by current members. The communications person reports to the organizer.



CANADIAN PONY CLUB

NATIONAL DRESSAGE RULES

2021

Loyalty

Character

Sportsmanship

8 SCORING

8.1 AWARDING MARKS

8.1.1 Marks awarded for each movement are from 1 to 10. Each mark has an assigned coefficient and must be multiplied. The marks given for each movement and General Impression or Collective Marks are then added together, then penalties for errors or other penalties occurring during the test are deducted. This is the positive score for the test. These points are converted into percentage scores. If a rider is eliminated during the test, that rider receives no score and is ineligible for an award.

8.1.2 To obtain the percentage of the test:

Example: 220 = Possible Marks
 133 = Achieved Marks (Total Points)
 -2 = Penalty for Error
 131 = Total Positive Points (Final Total)
 131 divided by 220 and multiplied by 100 = 59.545 %

The Final Score = 59.545 %. (must be to 3 decimal points)

Note: that although errors of voice are unlimited, errors of course and test are limited to two. On the third such error the rider is eliminated. Judges should NOT continue to mark such a test but often do in order to offer the rider an opportunity to learn. Upon elimination/disqualification, scores should not be posted.

- 8.1.3 Scorers must ensure that all movements are marked, the sheets are signed and any changes are initialed. If any of the above are missing, sheets must be returned to the judge for completion.
- 8.1.4 Marked sheets are considered to be the confidential property of the competition until they are handed over to the competitor. At that time, they become the private property of the competitor. The Show Organizers are obliged to post total points and percentages from the tests.
- 8.1.5 In order to maintain a record of marks, scorers must retain all individual marks from each test on a master sheet, to be available for queries. This master sheet may be on paper, or if a computer program is used it may be retained within the program. Tests may be released to riders immediately after the final ride of the class. It is recommended that awards not be presented for an hour after the class in order to allow riders to confirm their scores. Corrections of errors in math may be made at any time, however awards will not be changed after the show is formally over with the exception of Champion and Reserve Champion.
- 8.1.6 Should more than one Judge be used, the total positive points and percentages from each Judge are posted and the average of these is posted as the final score.



CANADIAN PONY CLUB

NATIONAL DRESSAGE RULES

2021

Loyalty

Character

Sportsmanship

8.1.7 Should there be only one horse in the class, the competitor must compete against the rulebook, which declares that in order to achieve a placing a particular score must be achieved as shown below.

First place requires a score of 60% or higher

Second place requires a score of 57% to 59.9%

Third place requires a score of 54% to 56.9%

Fourth place requires a score of 51% to 53.9%

No ribbons or prizes will be awarded for scores less than 51% or to placings lower than fourth.

8.2 TIES

8.2.1 Should a tie occur at a Dressage Competition, the competitor achieving the highest marks in the General Impression/Collective Marks is declared the winner.

8.2.2 If the tie still exists, they shall remain tied. The next placing shall be omitted (i.e., if tied for third, the next placing shall be for fifth, not fourth place).

8.3 QUERIES

8.3.1 A query may be made to the Show Steward or the Show Organizer regarding elimination, the marks of a competitor or an incident occurring, which may give rise to a query, without necessitating an Official Protest. Should the answer received not be to the satisfaction of the District Commissioner, Team Captain or the competitor then an Official Objection may be lodged.

8.3.2 Queries must be addressed ONLY to the Organizer or Show Steward, not to the Scorers or the Judge, and must be made by the Branch District Commissioner; delegated Branch official or delegated Regional official, not by the rider, parent or coach. Please refer to the CPC Harassment Guide.

8.4 OBJECTIONS

8.4.1 Only the Branch District Commissioner or delegated Branch official may lodge an objection.

8.4.2 Objections must be made to the Show Secretary of the competition in writing and accompanied by a deposit of \$50 no later than half an hour after the occurrence which gave rise to the objection, or where marks are concerned, within one hour of the issue of such marks. The deposit is forfeit unless the objection is upheld.

8.4.3 The decision of the Ground Jury is final.



CANADIAN PONY CLUB

NATIONAL DRESSAGE RULES

2021

Loyalty

Character

Sportsmanship

8.4.4 The query or objection may arise due to a lack of clarity in the CPC Dressage Rulebook. In such case the objection should be forwarded to the National Dressage Chair. The decision of the Ground Jury will not be over turned; however, a valid observation or comment may lead to a clarification of the Rulebook by the CPC National Dressage Committee.

8.5 STABLE MANAGEMENT

8.5.1 Stable Management judging includes an assessment of the way in which riders and grooms care for their horses, prepare their horses for the test to be ridden, and cool out the horses after the test. The warm-ups for each test are a part of the competition.

Grooms will work in accordance with the competitor as a team with specific assigned responsibilities for which they are scored but a portion of the overall stable management score for the team will be attributed to the competitor's stable management score.

8.5.2 Stable Management Judges should discuss expectations with the competitors prior to the start of the judging. The purpose of this competitive section of the competition is to give to the competitors an opportunity to demonstrate the practical aspects of horse care and stable work that they will have been taught, through their Branch activities.

8.5.3 Time must be provided on the day of the competition for the Stable Management Judges to address the competitors.

8.5.4 Tack rooms will not be judged for colour, artistic achievement, originality, etc. Safe, clean and workmanlike tack rooms are all that is required.

8.5.5 Checks of horses and tack should generally be made only in the presence of either the rider or the Groom, to allow the judge to point out why a penalty is assessed and written explanation should be provided on the daily Stable Management sheet.

8.5.6 In case of infractions which cannot be assessed against an individual for lack of evidence, the penalty points should be assessed against the Team. (Overall Impression - Team: on daily Stable Management Assessment Sheet).

8.5.7 Stable Management penalties assessed must be posted each day on master score sheet.



CANADIAN PONY CLUB

NATIONAL DRESSAGE RULES

2021

Loyalty

Character

Sportsmanship

9 CANADIAN PONY CLUB DRILL TEAM RULES

9.1 COMPETITIVE LEVELS

STARTER

Objective is to introduce the drill team to competition. Test is to be performed at the walk and trot. Team should perform in a calm obedient uniform manner, maintaining even spacing. Appropriate figures for the level are shown on the score sheet. Tests may be performed at either sitting or rising trot, but the group should be uniform. Time limit is 6 minutes in the 20x40 ring for the National Championship.

PRE-TRAINING

Objective is to exhibit a higher degree of difficulty and to introduce the canter. Horses should move freely and energetically forward stretching onto the bit and maintaining an even tempo. Team should maintain even spacing and perform in a uniform manner. Appropriate figures for the level are shown on the score sheet. Test may be performed at either sitting or rising trot, but the group should be uniform. Time limit is 7 minutes in the 20x60 ring for the National Championship.

PRELIMINARY

Objective is to exhibit a higher degree of difficulty in both formations and technical movements required. Horses should be calm, obedient, move freely and energetically forward stretching onto the bit and maintaining an even tempo. Team should maintain even spacing and perform movements in a uniform manner. Appropriate figures for the level are shown on the score sheet. Test to be performed at sitting trot. Time limit is 8 minutes in the 20x60 ring for the National Championship.

INTERMEDIATE

Objective is to exhibit a higher degree of difficulty in both formations and technical movements required. Horses should be calm, obedient, move freely and energetically forward stretching onto the bit and maintaining an even tempo. Team should maintain even spacing and perform movements in a uniform manner. Appropriate figures for the level are shown on the score sheet. Test to be performed at sitting trot. Time limit is 9 minutes in the 20x60 ring for the National Championship.

ADVANCED

Objective is to exhibit a higher degree of difficulty in both formations and technical movements required. Horses should be calm, obedient, move freely and energetically forward stretching and remaining on the bit and maintaining an even tempo. Team should maintain even spacing and perform movements in a uniform manner. Appropriate figures for the level are shown on the score sheet. Test to be performed at sitting trot. Time limit is 10 minutes in the 20x60 ring for the National Championship.



CANADIAN PONY CLUB

NATIONAL DRESSAGE RULES

2021

Loyalty

Character

Sportsmanship

9.2 GENERAL DRILL TEAM RULES

- 9.2.1 Teams are not required to submit a copy of their test pattern in advance.
- 9.2.2 The Drill Team is to be performed in a 20x40 ring or 20x60 as shown above, from memory.
- 9.2.3 Whistles may be used either by a caller on the ground or by a mounted rider to command the team.
- 9.2.4 Teams are to salute the judge at C at the beginning and end of all tests.
- 9.2.5 Whips are optional. Boots or bandages may be used but must be worn by all horses on the team.
- 9.2.6 Riders should be in matching outfits.
- 9.2.7 Formal riding jackets are optional.
- 9.2.8 Spurs are optional but must be blunt. Roweled and offset spurs are not permitted. Spurs must be made of metal and conservative in colour.
- 9.2.9 Approved helmets, gloves, CPC pins and medical armbands are mandatory.
- 9.2.10 The bell/whistle will NOT be sounded at the time limit.
- 9.2.11 Any movement performed after the time limit has elapsed will not be scored.
- 9.2.12 Two points will be deducted for exceeding the time limit by more than ten seconds.
- 9.2.13 Timing begins and the test is judged from the move-off after the initial halt and salute.
- 9.2.14 Timing and judging will cease at the final halt.
- 9.2.15 Due to rime restrictions, each movement is NOT required on both left and right reins.
- 9.2.16 There will be four penalty points deducted for each movement above the level of difficulty of the competitive level entered.
- 9.2.17 Should the music fail due to technical failure (as opposed to a disc failure) the ride shall stop and be rescheduled at the end of the class.

9.3 DESCRIPTION OF DRILL TEAM MOVEMENTS

- 9.3.1 Oblique onto centre line: entire file is on the outside track, from their respective positions on the Track, each member turns onto a short diagonal to the centre line to re-create the file on the centre line.
- 9.3.2 Oblique across the arena: entire file is on the outside track, from their respective positions on the track, each member turns onto a short diagonal to cross the arena to the opposite track, having passed between members of the opposite file.
- 9.3.3 Cross-over: entire line is on the outside track, from their respective positions on the track, each member turns across the arena to pass between members of the other file and turn onto the opposite outside track in whichever direction is required.



CANADIAN PONY CLUB

NATIONAL DRESSAGE RULES

2021

Loyalty

Character

Sportsmanship

9.3.4 Thread the needle: entire file turns onto the long diagonal one at a time and passes over the centre line between members of the opposite file, returning to the track on the opposite side having changed the rein.

9.3.5 Pin wheel: two files facing in opposite directions rotate about the centre line.

10 CANADIAN PONY CLUB FUNDING AND DEVELOPMENT

10.1 Hosts of National Championships (in-person events only) are eligible for “host” grants.

10.2 Each host Region must file a request for the grant with the National Dressage Chair prior to June 1st of the host year.



CANADIAN PONY CLUB

NATIONAL DRESSAGE RULES

2021

Loyalty

Character

Sportsmanship

ORGANIZERS' HANDBOOK

APPENDIX A: CHECK LIST & TIME PLAN FOR RUNNING A DRESSAGE COMPETITION

A.1 INITIALIZE (6 MONTHS AHEAD)

- A.1.1 Set up Show Committee and appoint Secretary/Treasurer.
- A.1.2 Decide on type and level of competition.
- A.1.3 Select date, preferably by the autumn previous to the year of competition.
- A.1.4 Select and book Judges (test and stable management) and Stewards. Determine all costs (travel, hotel, meals, etc. and fees)
- A.1.5 Send out contracts to officials and facilities.
- A.1.6 Arrange for Farrier and Veterinarian.
- A.1.7 Solicit potential sponsors.
- A.1.8 Arrange for stabling.

A.2 FOLLOW UP (4 MONTHS AHEAD)

- A.2.1 Arrange for possible billets for members.
- A.2.2 Choose tests (current) for all levels offered.
- A.2.3. Confirm contracts are signed and received.
- A.2.4 Decide on entry Closing date.
- A.2.5 Estimate possible number of entries and decide on number of rings needed, etc. Decide if it will be necessary to limit entries.
- A.2.6 Arrange for Insurance, if required.
- A.2.7 Draw up a PRIZE LIST and submit for approval to Show Steward if required for permit.
- A.2.8 Order Ribbons and Trophies.
- A.2.9 Post dates on CPC National website if National Championship

A.3 FINALIZE (3 MONTHS AHEAD)

- A.3.1 Apply for EC permit from the Provincial Equestrian Federation of Horse Council (if required) by submitting EC Official Competition Request Form, insurance certificate, prize list approval form and relevant fees.



CANADIAN PONY CLUB

NATIONAL DRESSAGE RULES

2021

Loyalty

Character

Sportsmanship

- A.3.2 Delegate tasks (catering, stabling, hospitality, volunteers, administration, etc.)
- A.3.3 Assure eligibility of officials and submit Guest Card Request Forms if required for permit.
- A.3.4 Post dates on CPC Regional website if a Branch or Regional competition.

A.4 POLISH UP (2 MONTHS AHEAD)

- A.4.1 Submit 3 copies of final approved prize list to PEF/HC
- A.4.2 Distribute prize lists and entry forms to competitors.
- A.4.3 Place advertisements as deemed necessary.
- A.4.4 Arrange accommodation for Judge(s) and Steward for night prior to competition, and other nights, if needed.
- A.4.5 Confirm caterers.
- A.4.6 Prepare tests – expected number of competitors plus judge(s) plus a few extra.
- A.4.7 Make sure of Dressage Rings and letters for sizes of rings. Also, for a warm up ring.
- A.4.8 Confirm availability of competitors' numbers.
- A.4.9 Finalize volunteers: Scribes, Scorers, Gate People, 'Whipper-In', Runners (to take tests to scorers).
- A.4.10 Arrange for Safety Steward, Safety Officer, traffic control, Stable Management judge, awards presenters.
- A.4.11 Confirm suitable medical personnel and ambulance if necessary.
- A.4.12 Check toilet facilities and/or order portable toilet.
- A.4.13 Pick up Ribbons and Trophies. Check for accuracy.

A.5 CLOSING DATE (2 WEEKS AHEAD)

- A.5.1 Check that all basic equipment is available and in sufficient quantity. (i.e.: Judges, Timers, Ring Space, Stabling, bells, whistles, tables, chairs, pens, paper, posting results, etc.)
- A.5.2 Set up Competition Schedule (starting times) allowing test time plus 1 to 2 minutes per test, to allow horse to leave the ring and the Judge to finish marking the test sheet. Allow Judges a 10-minute break every 15 tests, and between divisions. Remember that Judges are limited in how long they can work, check the current EC rulebook. Try to arrange the classes in increasing order of difficulty.



CANADIAN PONY CLUB

NATIONAL DRESSAGE RULES

2021

Loyalty

Character

Sportsmanship

- A.5.3 Arrange starting order. If a rider is riding more than one test, make sure there is no conflict by allowing as much time as possible between tests, a minimum of 20 minutes. Try to start and end the day with those that travel the least distance.
- A.5.4 Allot stabling.
- A.5.5 Assign numbers as the entries come in.
- A.5.6 Ensure computer scoring programs are functional.
- A.5.7 Ensure master sheets and master score sheets are prepared.

A.6 COMMUNICATION (48 HOURS AHEAD)

- A.6.1 Man telephones for release of STARTING TIMES. Inform early starters of their times.
- A.6.2 Check on all minor officials and tell them when and where they are needed.
- A.6.3 Confirm calculators are functional.

A.7 CONFIRMATION (24 HOURS AHEAD)

- A.7.1 Harrow or otherwise prepare dressage area.
- A.7.2 Mark out arena(s) with cord and tent pegs, etc., 20 x 60 metres.
- A.7.3 Set up ring(s) being sure that both the 20 x 40 and 20 x 60 rings are prepared in accordance to the rules. Refer to diagrams in this rulebook (Section B of Handbook) for guidance.
- A.7.4 The 20 x 40 ring is required for Entry, Starter and Pretraining at all shows. The 20 x 60 ring is required for all levels from Training level and above.
- A.7.5 Mark out warm up area or ring.
- A.7.6 Post stabling lists.
- A.7.7 Post starting times and prepare envelopes for each competitor containing start times, number and a program, if one is available. Include sponsor material.

Prepare equipment for next day as follows:

- A.7.8 Each Judge should be provided with:
 - a) a shelter with a table and two chairs, or a pickup truck with a clean windshield. These facilities should be arranged so that the Judge can sit directly behind the letter to which he/she is assigned.
 - b) Clip board with a copy of each test he/she will be judging
 - c) A cooler with food and water.



CANADIAN PONY CLUB

NATIONAL DRESSAGE RULES

2021

Loyalty

Character

Sportsmanship

A.7.9 Scribes should be provided with:

- a) a clipboard with sufficient tests for the number of entries in each class, plus a couple of extras.
- b) pens and paper, hand bell or whistle (if rings are side by side, one should have a bell and the other a whistle, to prevent confusion), fly spray or blanket (depending on the season), competition schedule including any scratches or changes.
- c) A cooler with food and water is a nice touch.

A.7.10 Steward requires a clipboard with competition schedule and changes, pen, chair, fly spray, assistant (if a large number of entries).

A.7.11 Whipper-In and Gate Opener both require clipboards with the competition schedule, chair, pens and whatever they need for comfort.

A.7.12 Show Secretary requires:

- a) a quiet but readily accessible area with table and chairs, or covered area if bad weather.
- b) Competitors envelopes with numbers and schedule (start times).
- c) Spare copies of each test.
- d) Account of money paid, owing or overpaid. (Should be on outside of Competitors' envelopes.)
- e) Cash for refunding number deposits.
- f) Stabling information.
- g) Rule Books.
- h) Ribbons and Trophies – sorted and in order.
- i) A reliable laptop makes life easier.

A.7.13 Scorers require:

- a) a quiet area with table and chairs (less accessible), protection from wind and glare of sunlight;
- b) score sheets,
- c) pad of foolscap for notes
- d) pens, pencils, erasers if calculating by hand or calculator
- e) posting results sheets if done by hand,
- f) two calculators, one with tape, or a computer program and one calculator with tape
- g) stapler and staples,
- h) start sheets (order),
- i) reliable runner to fetch tests from Judges, etc.



CANADIAN PONY CLUB

NATIONAL DRESSAGE RULES

2021

Loyalty

Character

Sportsmanship

j) reliable power source for computers and calculators

A.7.14 Announcer requires:

- a) loud hailer or loud speaker,
- b) corrected Competition Schedule
- c) official clock which determines official show time
- d) list of classes, sponsors and volunteers for thank-you announcements.

A.7.15 Officials will require refreshments and meals during the competition as well as toilet breaks. Also, comfort items such as mosquito repellent, fly spray, hand washing facilities etc.

A.7.16 EC passports for horses are not needed at EC primary permit shows.

They are mandatory at EC Provincial Circuit and National Shows.

No CPC show requires more than a primary permit.

A.7.17 Suitable equipment for the repair and maintenance of the ring (more fencing, tractor & harrow, mower).

A.7.18 Sponsorship volunteer needs to be prepared to play host to sponsors, ensure they are available at the ribbon presentation and that their generosity is being announced.

A.7.19 Awards volunteer needs a spot to arrange ribbons and awards.

A.7.20 Prepare thank-you notes and cheques for officials and facilities.

A.8 COUNT DOWN

A.8.1 60 minutes Show Secretary on duty to give out numbers, etc.

A.8.2 15 minutes Whipper-In should locate first three (3) competitors and make them aware of the time, ensuring that the first rider is ready to enter the arena.

A.8.3 10 minutes Install all Officials.

A.8.4 5 minutes First competitor approaches arena.

A.8.5 0 minutes First competitor is called into the arena.

A.8.6 At this time the Organizer should check for trouble spots:

Gate People, Stewards/Tack Check, Safety Officer, Medical Personnel, Competitors, Secretary, Scorers, Runners (or Gopher), Judges, Refreshments.



CANADIAN PONY CLUB

NATIONAL DRESSAGE RULES

2021

Loyalty

Character

Sportsmanship

A.8.7 Encourage 'runners' to pick up tests after every ride and ask scorers to keep scores posted on the score board where riders can see them, right up to date. Do not post placings until after the last score is posted.

A.8.8 Make presentations as soon as a reasonable protest time has passed (i.e. 1 hr. after completion of class and release of tests).

A.8.9 Tests may be released to competitors immediately after the class is completed. Master sheet of results is maintained by scorers should there be a dispute over marks.

A.9 ON COMPLETION OF COMPETITION

A.9.1 Within 24 hours: Clean up the facility and stabling area.
Return all borrowed equipment.

A.9.2 Within 2 days: Finish all paper work.
Pay all outstanding accounts.
Collect outstanding fees.
Post results on web site.

A.9.3 Within 7 days: Pay required fees to Provincial Equestrian Federation or Horse Council as required (i.e. test user fees for EC tests only, drug test fees, anything they invoice you for).



CANADIAN PONY CLUB

NATIONAL DRESSAGE RULES

2021

Loyalty

Character

Sportsmanship

APPENDIX B: ARENAS AND MARKERS

B.1 COMPETITION ARENAS

- B.1.1 A plan of the arena appears in this rulebook. It should be sited on level ground with firm, but soft, footing.
- B.1.2 It should be marked by wooden fencing, or other safe suitable material, about 0.30 metres high (approx. 1').
- B.1.3 The letters should be clearly visible over the fence and to the Judges.
- B.1.4 A gateway must be made at "A" that should be closed once the test has started.
- B.1.5 Arena fence conditions must be the same for all competitors in a class.
- B.1.6 A letter "A" should be placed 5 - 15 metres back to allow the horse to make a straight entry.
- B.1.7 The internal letters, "D", "X", "G", or "D", "L", "X", "I", "G", are not marked except that they may be cut into the grass or raked into the sand, depending on the type of footing in the arena. The centre line may be mown also.
- B.1.8 The letters outside the enclosure should be placed about 0.05 meters from the fence and clearly marked.
- B.1.9 In the absence of sand footing, a grass ring may be used if it is in good condition.
- B.1.10 Spectators should be 15 metres from the enclosure outdoors and 3 metres indoors. Indoors the arena should be placed a minimum of 2 metres from the wall.
- B.1.11 Judges must be 5 metres from the enclosure.
- B.1.12 Any signage from sponsors must not be on the short side at C, and must be no less than 1.5 m on either side of A, no less than 3m on either side of E or B. Signage must be placed symmetrically around the competition arena and must be of a type that will not interfere with the performance of the horse.
- B.1.13 The senior Judge is to be placed at C. The second judge may be placed at either E or B. The third judge may be placed at either M with the E judge or H with the B judge. Should there be five judges they are to be placed in accordance with FEI rules.
- B.1.14 Each competition arena requires its own Show Steward, Whipper-in, Gate Attendant, Judge, Scribe and runner.



CANADIAN PONY CLUB

NATIONAL DRESSAGE RULES

2021

Loyalty

Character

Sportsmanship

B.2 WARM-UP AND SCHOOLING ARENAS

- B.2.1 Wherever possible, the footing of the warm-up ring should match that of the competition arena.
- B.2.2 It is recommended that the warm up area be no closer than 10 m from the competition arena.
- B.2.3 The warm-up area should be the minimally the same size as the competition arena (i.e. 20x40 or 20x60)
- B.2.4 Lunging is not permitted in the warm-up or schooling areas where mounted riders are present for reasons of safety. It is recommended that a designated lunging area be posted.
- B.2.5 Each warm-up or schooling arena requires a Safety Steward and must be within sight of the Show Steward attending the corresponding competition arena.



CANADIAN PONY CLUB

NATIONAL DRESSAGE RULES

2021

Loyalty

Character

Sportsmanship

20 X 40 DRESSAGE ARENA

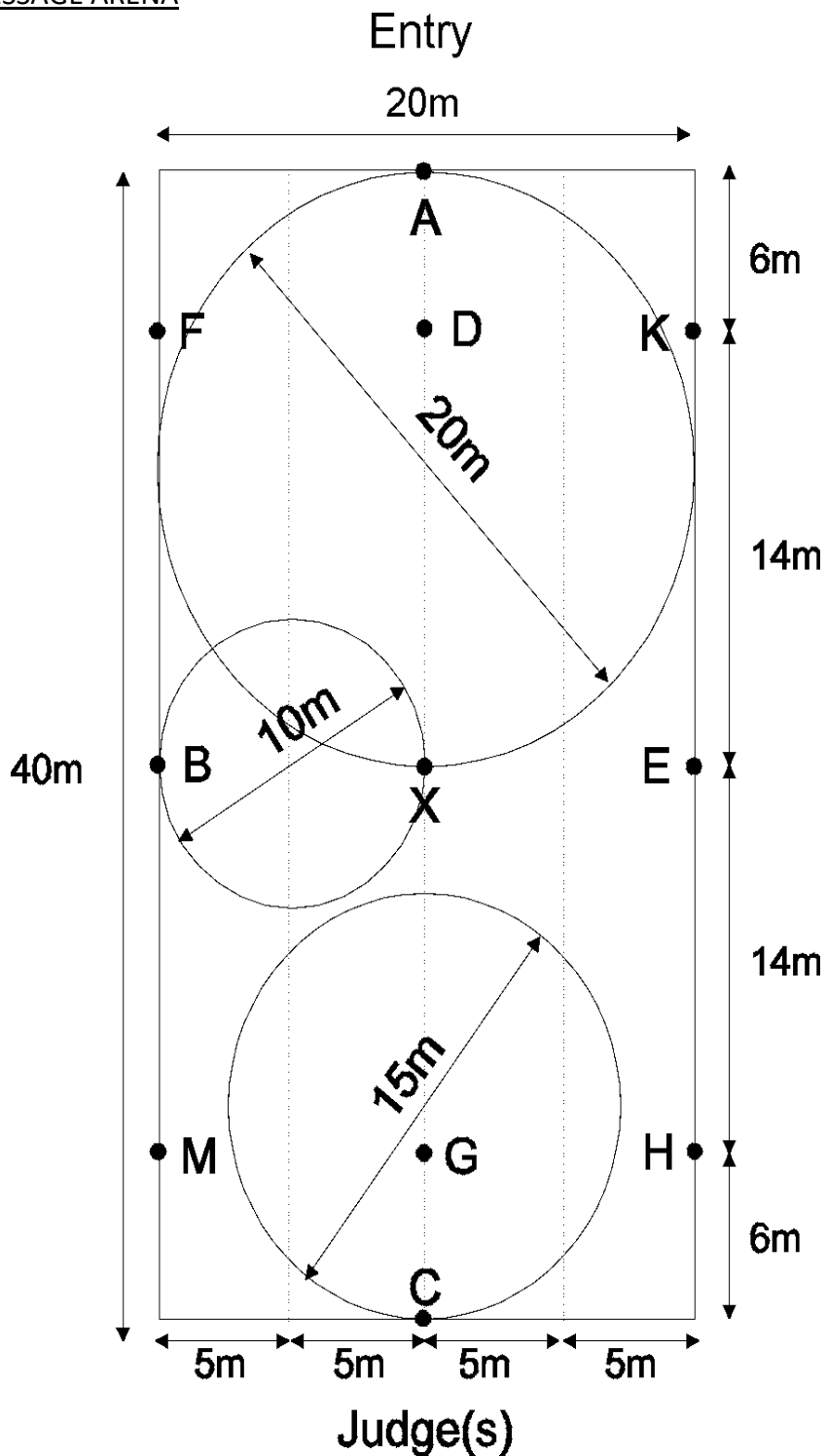



CANADIAN PONY CLUB

NATIONAL DRESSAGE RULES

2021

Loyalty

Character

Sportsmanship

20 X 60 DRESSAGE ARENA

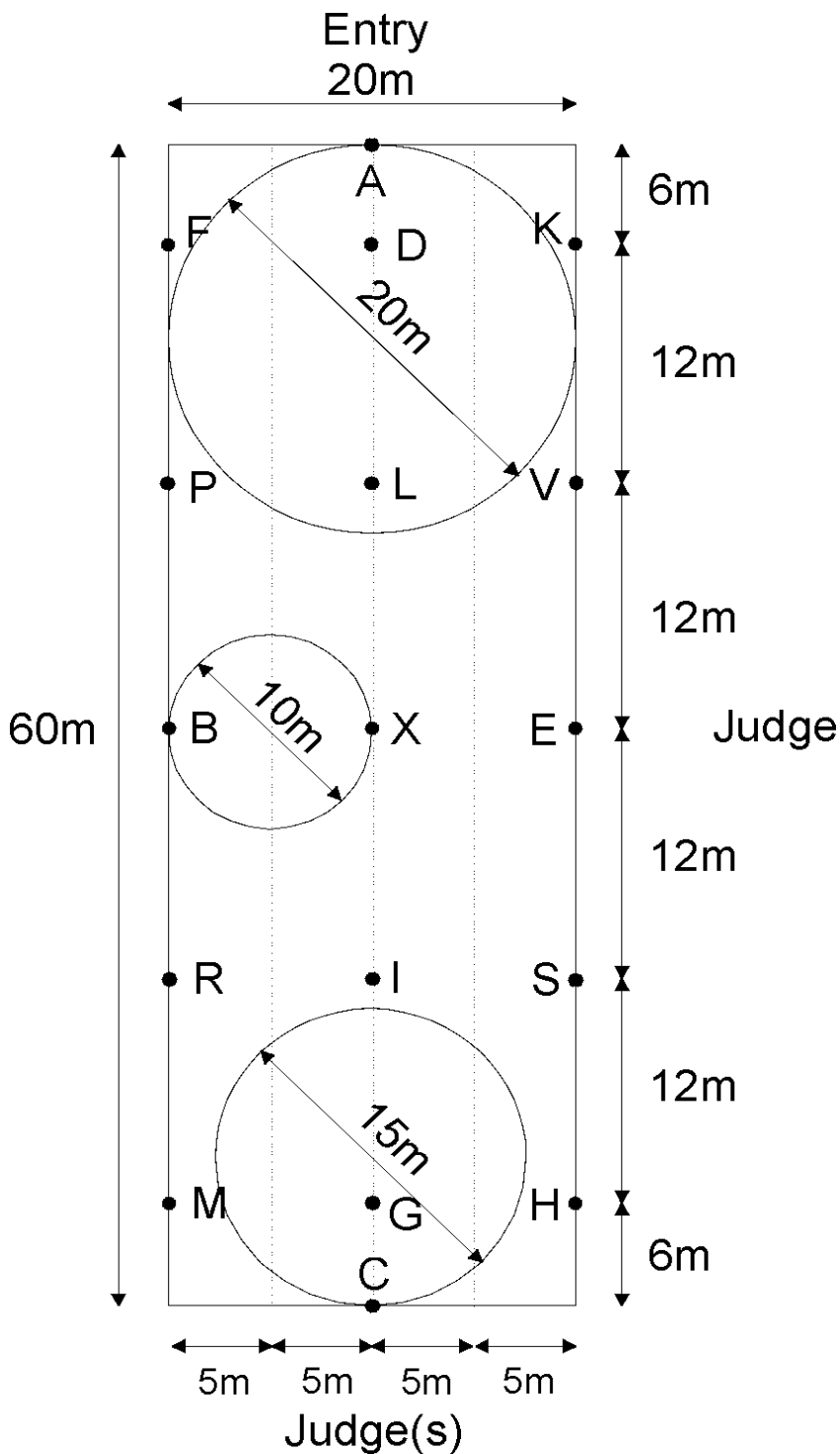



CANADIAN PONY CLUB

NATIONAL DRESSAGE RULES

2021

Loyalty

Character

Sportsmanship

APPENDIX C: PRIZE LIST REQUIREMENTS

The prize list for the show must include the following information:

- C.1 name of the organization (Branch/Region) responsible for organizing the show;
N.B. It is important to note that only one organization may be in charge of the show – shared shows are **NOT** covered by the CPC insurance policy
- C.2 reference to CPC and a statement that the show is run in accordance with CPC rules and policies and that these rules and policies apply to all competitors (regardless of membership, spectators, coaches, and volunteers;
- C.3 specify if show is open to non-CPC members; **Please ensure that if your competition allows non-CPC members to enter, that they are members of the appropriate Provincial Equestrian Federation or Horse Council and that you obtain proof of this membership. Such competitors MUST fill out a non-member acceptance of risk form;**
- C.4 if an EC permit is obtained, the name and address of the appropriate Provincial Equestrian Federation or Horse Council;
- C.5 if an EC permit is obtained, the requirements for membership to the Provincial Equestrian Federation or Horse Council for horse owners in addition to competitors;
- C.6 if an EC permit is obtained, the EC Code of Ethics and EC address;
- C.7 availability of appropriate dressage tests (publications, web sites, EC/provincial offices, etc.);
- C.8 address, fax and/or telephone of Show Secretary to whom entries are sent, as well as **closing date;**
- C.9 requirements for submitting entries (i.e. by individual, signed by DC, Regional Chair, etc.)
- C.10 list of classes, levels, divisions, awards and tests being judged, with ring size and footing as well as any limitations to any one class;
- C.11 time and telephone number at which riding times will be available;
- C.12 qualifications required for competition (i.e. previous scores, memberships);
- C.13 proofs required for entering (i.e. provincial federation memberships for horse owners and non-CPC members, Coggins tests, vaccinations, test scores, etc. as determined by host);
- C.14 specific rules and regulations of your organizing committee or landowner (i.e. dogs, tack check, if Championship rules are being applied and if so, which ones, or which are excluded);



CANADIAN PONY CLUB

NATIONAL DRESSAGE RULES

2021

Loyalty

Character

Sportsmanship

- C.15 names of officials (Judges, Stewards, Organizer, Secretary, Farrier, Veterinarian, etc.);
- C.16 entry and acceptance of risk forms for CPC members as well as for non-members if show is open.
- C.17 tentative schedule of classes, including requirements for awards presentations (i.e. mounted or not);
- C.18 information regarding availability of stabling including cost and contact number, food, accommodations including contact numbers, parking and camping.
- C.19 availability of schooling time in the rings;
- C.20 directions to facility;
- C.21 any special instructions or relevant information.



CANADIAN PONY CLUB

NATIONAL DRESSAGE RULES

2021

Loyalty

Character

Sportsmanship

NATIONAL / INTERNATIONAL ELIGIBILITY CHART

Membership	
National	Active
International	Active
Age	
National	13 prior to Jan. 1 of the competition year
International	As per invitation
Rating	
National	Training+ = D1+
International	As per invitation
Qualifying Period	
National	Previous year
International	Previous year
# and type of Qualifiers	
National	Regional Finals or Regions to determine how to qualify the competitors if no Regional Finals are held.
International	National Championships
Verification of Results	
National	Regions to choose participants based on Regional Rules/Criteria. National to confirm active status, age and testing as a backup to the Regional Dressage Chair. Send entries to National at receipt of first Notice and again 3 weeks prior to the competition.
International	Results sheet from Nationals
Min Performance	
National	58%
International	50%
Required Documents	
National	Entry Forms
International	National Package
Signatures	
National	Regional Chair and Regional Dressage Chair. The Regional Chair will sign a general declaration that they are aware that the competitor is competing at the event.
International	Regional Chair, Regional Dressage Chair, National Dressage Chair



CANADIAN PONY CLUB

NATIONAL DRESSAGE RULES

2021

Loyalty

Character

Sportsmanship

Letters of Reference

National Three letters from individuals familiar with the requirements and the applicant (not a family member) e.g. DC, coach, competition official, examiner, addressing the following: Rider maturity, ability to take direction from a coach/chaperone other than their own, experience riding a horse unfamiliar to them in competition.

International DC, Coach, NDC

Medical Fitness

National If a member has an illness, injury or medical condition that may interfere with their ability to participate fully, a medical certificate may be required.

International If a member has an illness, injury or medical condition that may interfere with their ability to participate fully, a medical certificate may be required.

